



YOKOHAMA

TRUCK AND BUS RADIALS

2024 ▶ 2025



For information about the EU Tyre Label, tyre labelling data and further technical details, see the corresponding sections inside this catalogue or price list respectively. You can also refer to the YOKOHAMA website www.yokohama.eu (not for country specific product and size availability).

TECHNOLOGIES TO GIVE YOU THE ADVANTAGE!

YOKOHAMA's Concept

Fleets today need more miles, greater retreadability, longer even-wear and less maintenance costs per kilometre from their tyres. Given the extreme demands of today's transport industry, continuous innovation in tyre technology is essential. YOKOHAMA's technologies help you get the most out of your tyre investments.

Tyre Construction

Tread

Compounds used in the tread depend on the tyre's specific application needs. YOKOHAMA has chosen various compounding strategies to minimise treadwear rate, and maximise traction, fuel efficiency, and resistance to fatigue, chipping and scaling.

Belt Edge Cushion

YOKOHAMA tyres feature a belt edge cushion to help prevent separation of the belt edges, and therefore the tread, caused by the scissoring effect of the belts.

Inner Liner

YOKOHAMA's inner liner is specially designed to minimise air seepage into adjacent areas of the tyre. The quality of the inner liner is critical to prevent air from penetrating into the casing. YOKOHAMA's special inner liner compound ensures a significantly longer casing life.

Bead Filler

Two or more different compounds are used in YOKOHAMA's bead filler (apex rubber) to stiffen the bead for steering response and to control the flexibility of other parts of the tyre.

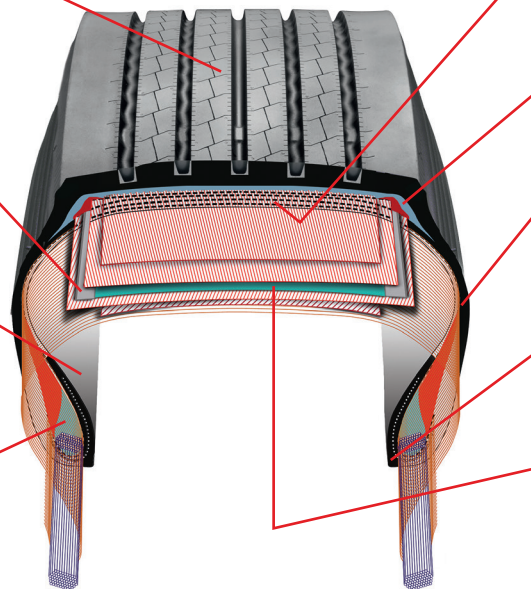

Belts and Casing

Thin, highly adhesive assembly compounds are used in YOKOHAMA's tyre casing and belts to prevent separation of the steel cords.

Undertread

YOKOHAMA's undertread compounds have low heat-generating characteristics, which prevent tread separation.

Sidewall

YOKOHAMA's special sidewall compounds are selected for high flexibility, excellent durability and high resistance to fatigue and weather cracking.

Rim Cushion

YOKOHAMA's rim cushion compound is highly resistant to the heat transmitted by the rim.

Zero Degree Belt

The "SPIRALOOP" Belt Structure (at the moment for BluEarth 110L only) has excellent casing durability, minimises casing growth and improves uneven wear performance. It contains a joint-less, zero degree circumferential belt, added in between the conventional 2nd and 3rd belt.

Individual Technologies



SC* Groove
To improve the shoulder
"Step-Down Wear".

*SC : Stress-wear (uneven wear)
Control



SC* Sipe
To improve "river wear".

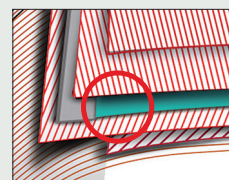

SPIRALOOP Construction
It minimises casing growth and improves uneven wear performance.



The Zenvironment Concept
A Concept for technological advancements aiming to reduce the environmental impact for tyres in several ways.

THE YOKOHAMA TBS PRODUCT LINEUP

Highway

 BluEarth 110L (M+S) <small>Depend on sizes</small> 107ZL RY407 <i>Steer Axle / All-Position</i>	 126S (M+S) <i>Steer Axle</i>	 BluEarth 707L (M+S) TY517E (M+S) <i>Drive Axle</i>	 RY357 (M+S) <small>Depend on sizes</small> RY253 <i>Trailer Axle</i>
--	--	--	--

Regional

 126S (M+S) <i>Steer Axle</i>	 124R (M+S) <i>(124RA)</i>	 104ZR	 121T (M+S)	 125T (M+S)
 RY103 <i>Steer Axle / All-Position</i>	 704R (M+S) <i>Drive Axle</i>	 Y785R	 RY357 (M+S) <small>Depend on sizes</small>	 RY253 <i>Trailer Axle</i>

City Bus and Coach

<small>CITY BUS</small> 120U (M+S) <i>Steer Axle / All-Position</i>	 RY537 (M+S) <i>Steer Axle / All-Position</i>	<small>COACH</small> 107ZL <i>Steer Axle / All-Position</i>	 124R (M+S) <i>Steer Axle / All-Position</i>
--	--	--	---

On and Off Road

 MY507 (M+S) <i>Steer Axle / All-Position</i>	 MY547 (M+S) <i>Steer Axle / All-Position</i>	 301C (M+S)	 LY717 (M+S) <i>Drive Axle</i>	 508T (M+S) <i>Trailer Axle</i>	 505C (M+S) <i>Trailer Axle / Steer Axle</i>
--	--	-----------------------	---	--	---

Winter*

 901ZS (M+S) <i>Steer Axle / All-Position</i>	 902W (M+S)	 SY397 (M+S)	 125T (M+S)	 508T (M+S)	 505C (M+S)	 MY507 (M+S)
<i>Steer Axle / All-Position</i>			<i>Drive Axle</i>		<i>Trailer Axle</i>	

YOKOHAMA ORIGINAL TREAD PATTERN CODES

RY: Rib (All-Position / Steer / Trailer)
 TY: Traction Block (Drive)
 MY: Rib / Lug (Mixed Service) (All-Position / Steer / Trailer)
 LY: Lug (Drive)
 SY: Snow / Winter

104ZR

- Pattern**
 - 1: Rib
 - 3: Lug
 - 5: Rib Lug
 - 7: Block (Traction)
 - 9: Snow, Winter
- Development Number**
01 to 99
- "Z"environment Series**
- Category**
 - L: Long Haul / Highway use
 - A: On & Off (All Terrain)
 - U: Urban
 - R: Regional
 - W: Winter
 - E: Environment Special
 - S: Steer Special
 - D: Drive Special
 - T: Trailer Special

NOTE

The availability of products and the special size range offered can vary from country to country. For detailed information about the available products and sizes offered in your country, the EU Tyre Label, tyre labeling data and further technical data, please see the corresponding sections in this catalogue or price list respectively or contact your local distributor or dealer. For basic information, you can also refer to the YOKOHAMA website www.yokohama.eu (not for country specific product and size availability).

Do not mix different tyre size designations or constructions on the same axle. Always use the tyres for their intended service purpose. Please consult your YOKOHAMA distributor for details as some vehicle operations require specialised tyre fitment. All technical information contained in these pages may be subject to change.

ADVANCED MIXING METHOD EXPLAINED

Lower Temperature / Higher Torque Mixing Method

An advanced compound mixing method has increased the durability of tyres.

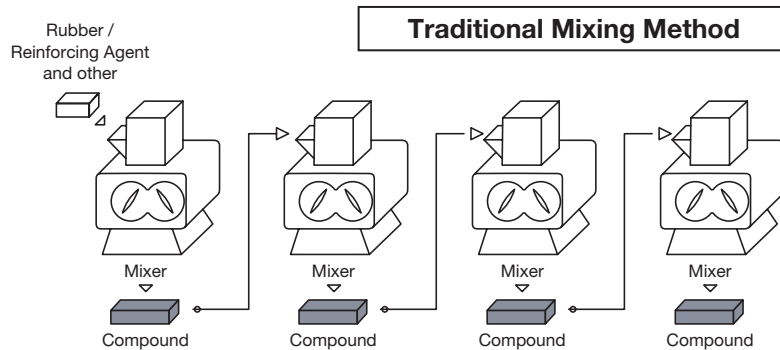

Multi-Step Mixing

The traditional multi-step mixing process mixes and kneads the rubber simultaneously. The long periods of mixing result in high temperatures, which tend to cause deterioration in the quality of the rubber.

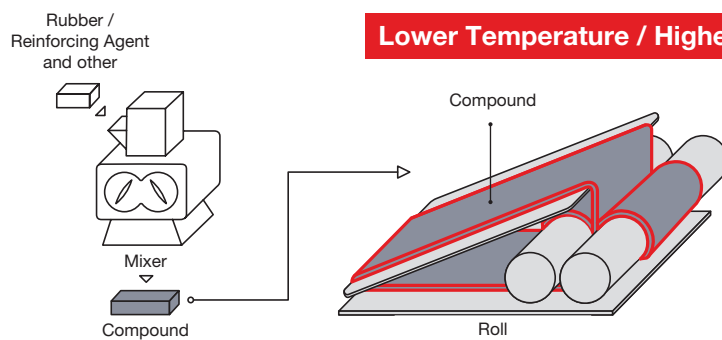

One Step Mixing & Roll Mixing

The advanced method performs the kneading of the rubber on rollers after the rubber has been mixed. This process results in lower temperatures. It thus minimises the splitting of the rubber's long polymer chains and promotes a more even distribution of the carbon black particles, which are used as a reinforcing agent.

Microscopic imagery reveals the improvement in rubber composition that results from the Lower Temperature & Higher Torque Mixing Method

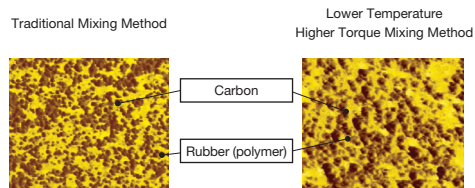

The distribution of carbon particles is more even in rubber produced with the Lower Temperature / Higher Torque Mixing Method process than in traditionally processed rubber.

Rubber Structure Model

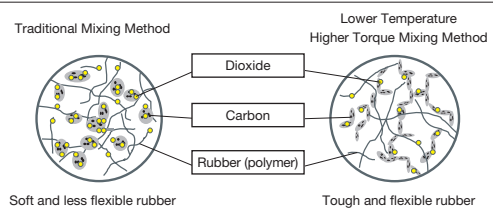

The Lower Temperature & Higher Torque Mixing Method significantly reduces dioxide obstacles and disperses carbon in rubber evenly.

Performance

Tyre Mileage

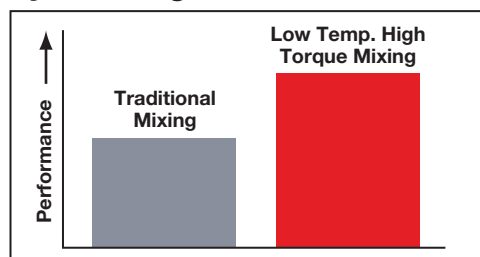

Compound Performance

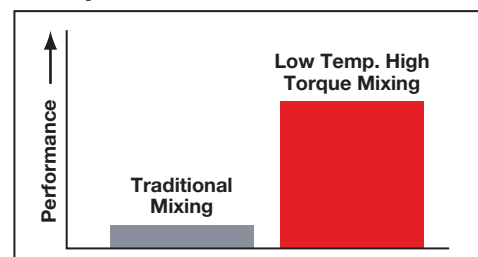

INTRODUCING YOKOHAMA TECHNOLOGIES

The E+ Concept

E+ The Mark of YOKOHAMA's EV Tyres

Tyres for electric vehicles (EVs) must fulfill unique requirements. These include the ability to deal with the heavy load of the battery and the uneven wear that tends to occur due to heavy loads and high torque output from the



motor, a level of quietness suitable for silent-running electric vehicles, and improved power and energy consumption efficiency to extend cruising range. We have introduced our own unique E+ mark to indicate that a passenger car, bus, or truck tyre is suitable for EV use, and will apply this to products going forward. By displaying the E+ mark, we clearly indicate to customers which products are compatible with electric vehicles so that they are able to choose the right tyre.

The BluEarth Concept

BluEarth. The Product Engineering Philosophy, which focuses on the idea of responsibility towards the Environment and Society constantly.



Our Philosophy, to keep the focus on the responsibility towards the Environment and Society.



The SPIRALOOP Concept

The innovative "SPIRALOOP" Belt Structure has excellent casing durability, minimises casing growth and improves uneven wear performance. It contains an advanced, joint-less, zero degree circumferential belt, added in between the conventional 2nd and 3rd belt.

Construction

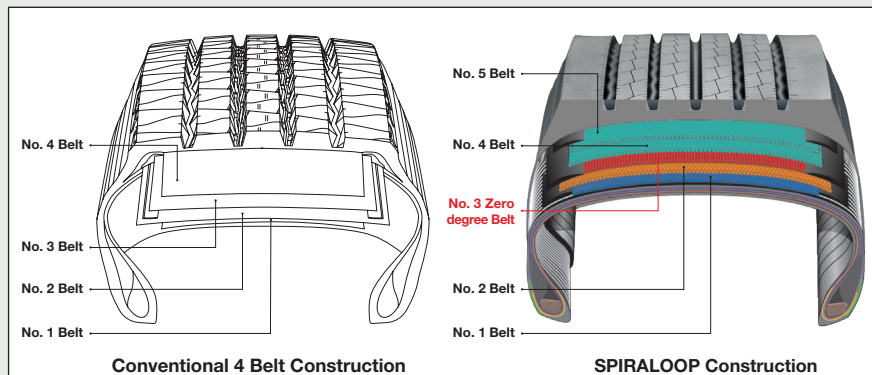

Comparison Example

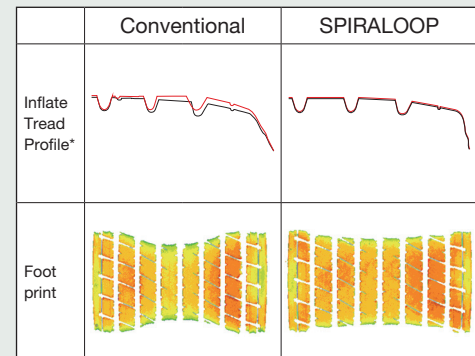

* red line: Inflated

example case of size 435/45R22.5

RECOMMENDATIONS FOR YOUR TYRE

Inflation Pressure

Truck tyres for commercial vehicles must be inflated to a pressure relevant to the load, speed and condition of use to produce maximum performance in aspects such as even wear (long mileage), traction and handling stability (riding comfort) in addition to safety issues*.

* Check YOKOHAMA's recommendations for inflation pressures in the corresponding section of this catalogue or price list respectively.

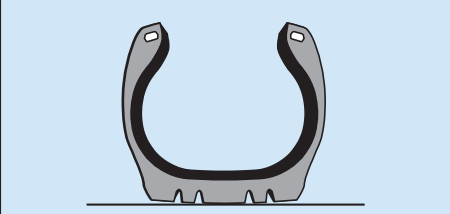
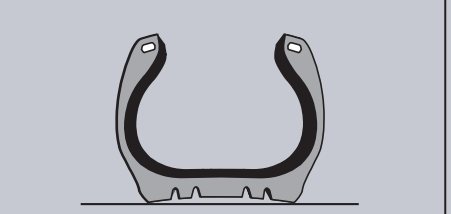
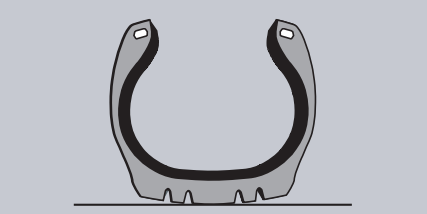
		
CORRECT INFLATION	UNDERINFLATION	OVERINFLATION
maintains even road contact for maximised performance.	causes abnormal tyre deflection, which builds up excessive heat, and risk of failure. It also causes excessive wear on the shoulder.	increases the risk of impact breaks and other road hazard damage. It also causes excessive wear in the centre.

Tyre pressures should be checked on cold tyres at least every two weeks, using a calibrated pressure gauge. Tyres with lower profiles must be checked strictly due to their less visible sidewall deflection.

YOKOHAMA provides "inflation pressure stickers" with several different values to help customers maintain proper pressures. Please contact your YOKOHAMA distributor for details.

8.50bar

Truck & Bus Tyres



125psi

Truck & Bus Tyres



Retreading

Every new YOKOHAMA truck tyre product is designed and constructed for better retreadability. In addition, YOKOHAMA casings are backed up by the special "CASING WARRANTY" available. Please consult your YOKOHAMA distributor for details.

Regrooving

Regrooving must be undertaken when only between 2 to 3 mm of the original tread pattern remains, in accordance with YOKOHAMA's recommendations in this booklet.

Winter Tyre Application

Winter tyres are normally designed with a fine, deep and wide tread to ensure traction on wintry roads. These products are not suited to hot and rough road surfaces. YOKOHAMA strongly recommends fitment of brand-new winter tyres for each winter season.

RECOMMENDATIONS REGARDING TYRE WEAR

Tyre Wear Factors

FUEL ECONOMY & THE ENVIRONMENT

These tables indicate factors of tyre wear. If all factors are taken into account and applied correctly according to your vehicle and situation, this will result in better fuel economy and aid in the protection of our environment.

INFLATION PRESSURE

• Tyre Mileage Index in %

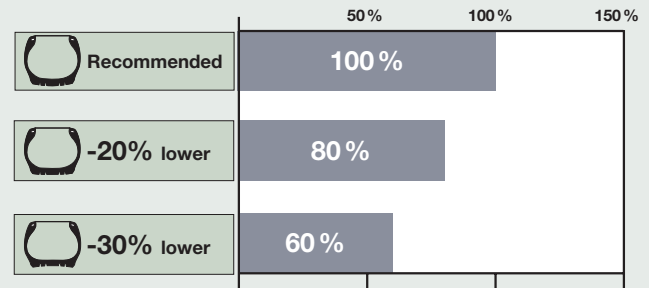

The proper inflation pressure is essential for the correct performance of all kinds of tyre. YOKOHAMA recommends proper maintenance and utilisation of a calibrated gauge / inflation pressure sticker or TPMS.

CARRYING LOAD

• Tyre Mileage Index in %

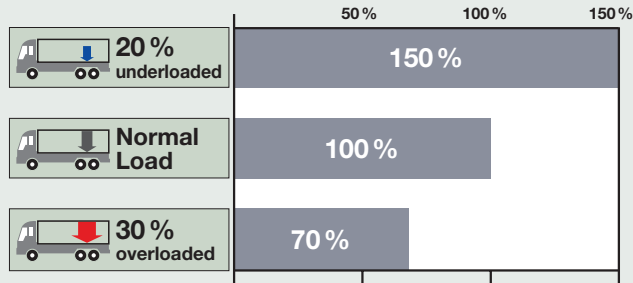

Tyre wear depends upon the load carried. YOKOHAMA recommends maintaining the correct axle and payloads.

STOP / GO OPERATION (Braking Abrasion)

• Tyre Mileage Index in %

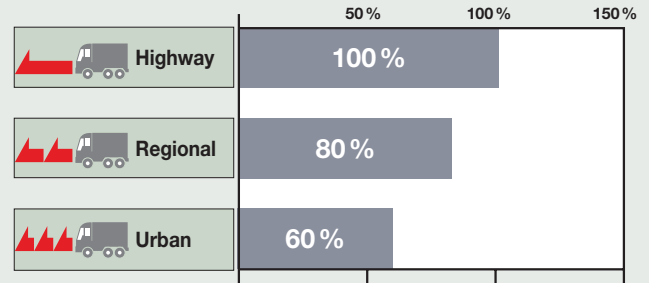

Rapid or frequent "stop and go" traffic results in additional stress and abrasion to tyres. YOKOHAMA recommends mild steering & braking especially while turning or curving in urban and local use.

SEASONAL / AMBIENT TEMPERATURES

• Tyre Mileage Index in %

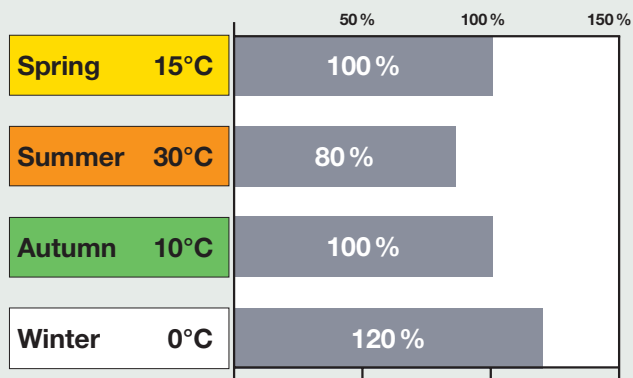

Tyre wear is temperature dependent. YOKOHAMA recommends carrying out a tyre service before the winter season.

TRAILER AXLES

• Tyre Mileage Index in %

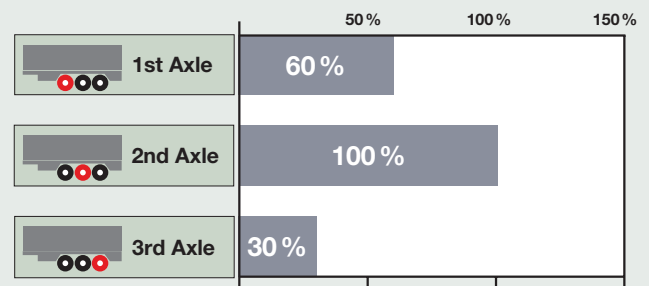

Trailer tyre wear is dependent on the sideforce of the axles of trailers. YOKOHAMA recommends proper tyre rotation when utilising retreaded tyres.



Steer Axle // All-Position



YOKOHAMA's advanced steer and all-position tyre, with innovative BluEarth concept and SPIRALOOP technology for highway operations.

M+S
Depend on sizes

SC Sipe

SPIRALOOP
Depend on sizes

- Zero degree joint-less circumferential direction belt controls the shoulder area casing growth to increase anti-irregular wear performance and shoulder area durability.
- Contact Pressure Equaliser Sipe to optimise rib contact pressure for anti uneven wear, handling and braking.
- Wavy Grooves to reduce stone damage and to improve uneven wear performance.
- SC-SIPE (Stress-Wear Control Sipe) design to reduce abnormal wear on rib edges.

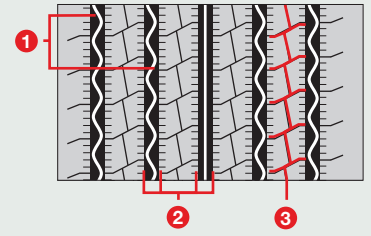

- 1 Wavy Grooves to reduce stone damage and to improve uneven wear performance
- 2 SC-Sipe to optimise rib edge contact pressure and to reduce rib edge uneven wear
- 3 Contact Pressure Equaliser Sipe to optimise rib contact pressure for anti uneven wear, handling and braking



EU Label Range	
Fuel Efficiency Class	C
Wet Grip Class	B-C
External Rolling Noise Class and Measured Value (dB)	A-B 67-73

These values are for the full size range of this product. The special size range offered can vary from country to country. For detailed information on the sizes offered and the relevant parameters in your country, please refer to the table section.

Steer Axle // All-Position



Advanced highway steer and all-position tyre, engineered with innovative "Zenvironment" technologies for ordinal highway operations.

SC Groove

SC Sipe



- Advanced tread compound under "Zenvironment" technology aims at mileage and fuel economy.
- YOKOHAMA's casing compound under "Zenvironment" technology aims to extend casing life for multi-retread.
- 6-rib tread design with over 6,000 sipes. This premium feature aims to provide water evacuation and uniform wear.

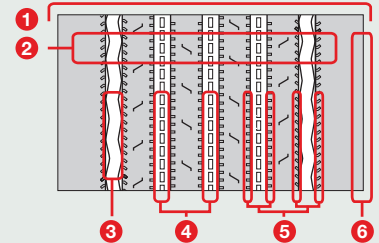

- 1 Tread design with special contoured design of the groove walls
- 2 Tread Compound / Deep Tread
- 3 Wavy Grooves
- 4 Stone Ejectors
- 5 SC (Stress-Wear Control)-Sipe
- 6 SC (Stress-Wear Control)-Groove



EU Label Range	
Fuel Efficiency Class	C
Wet Grip Class	B
External Rolling Noise Class and Measured Value (dB)	B 71

These values are for the full size range of these products. The special size range offered can vary from country to country. For detailed information on the sizes offered and the relevant parameters in your country, please refer to the table section, under the respective different categories (Highway / Coach).



4 grooves pattern version

Steer Axle // All-Position



Steer and all-position tyre, designed with YOKOHAMA's advanced technologies for highway operation.

- Advanced 6-rib tread design for even wear and traction.
- Casing construction to provide durability.

EU Label Range	
Fuel Efficiency Class	C
Wet Grip Class	C
External Rolling Noise Class and Measured Value (dB)	A 70

These values are for the full size range of this product. The special size range offered can vary from country to country. For detailed information on the sizes offered and the relevant parameters in your country, please refer to the table section.



Steer Axle

126S



YOKOHAMA's advanced steer tyre, designed for highway and regional operations.

- Serpentine and wavy grooves for traction, reduced shoulder step-down and irregular wear.
- Deep wavy sipes and shallow grooves for optimized contact pressure and anti-uneven-wear performance.
- Straight driving stability by rigid shoulder ribs with shallow design groove.
- Reduced stone bite and damage due to wavy grooves and stone ejectors.

EU Label Range

Fuel Efficiency Class	C-D
Wet Grip Class	B
External Rolling Noise Class and Measured Value (dB)	68-70

These values are for the full size range of this product. The special size range offered can vary from country to country. For detailed information on the sizes offered and the relevant parameters in your country, please refer to the table section under the respective different categories (Highway / Regional).



M+S

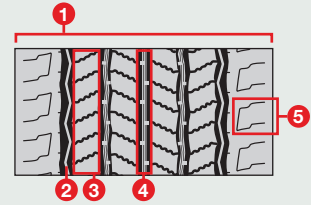

- 1 Wide tread design
- 2 Serpentine and wavy grooves
- 3 Deep wavy sipes and shallow grooves
- 4 Wavy grooves and stone ejectors
- 5 Rigid shoulder ribs with shallow design groove

Highway

Drive Axle

BluEarth 707L



Advanced long-haul drive axle tyre with innovative BluEarth concept for highway operations.

- Tread compound aiming for tread life and traction.
- Rigid shoulder ribs with shallow open lugs to improve uneven wear performance.
- Small pitch "Z-Blocks" for anti irregular wear performance and traction.
- Step grooves to reduce stone damage.

EU Label Range

Fuel Efficiency Class	C
Wet Grip Class	C
External Rolling Noise Class and Measured Value (dB)	72-73

These values are for the full size range of this product. The special size range offered can vary from country to country. For detailed information on the sizes offered and the relevant parameters in your country, please refer to the table section.



M+S

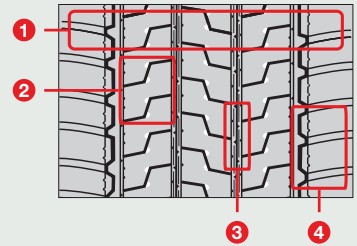

- 1 Directional pattern
- 2 Small pitch "Z-Block"
- 3 Step grooves
- 4 Rigid shoulder ribs with shallow open lugs

Drive Axle

TY517E



Drive axle tyre designed with YOKOHAMA's advanced technologies for highway operation.

- Deep & wide tread design.
- Alternated tread block design with 4-straight wide grooves to increase even wear.
- Shallow lug grooves at shoulder to minimise shoulder heel & toe wear.

EU Label Range

Fuel Efficiency Class	D
Wet Grip Class	B
External Rolling Noise Class and Measured Value (dB)	70

These values are for the full size range of this product. The special size range offered can vary from country to country. For detailed information on the sizes offered and the relevant parameters in your country, please refer to the table section.



M+S

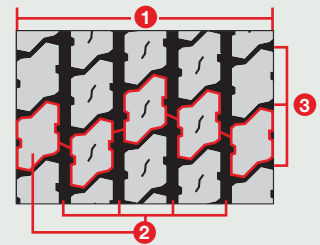

- 1 Deep & wide tread
- 2 Alternated tread block with 4-straight wide grooves
- 3 Shallow lug grooves

Trailer Axle

RY357



M+S Depend on sizes

Wide base highway/regional use tyre for the trailer axles.

EU Label Range

Fuel Efficiency Class	B-C
Wet Grip Class	A-B
External Rolling Noise Class and Measured Value (dB)	68-69

These values are for the full size range of these products. The special size range offered can vary from country to country. For detailed information on the sizes offered and the relevant parameters in your country, please refer to the table section, under the respective different categories (Highway / Regional).

Trailer Axle

RY253



Wide base highway/regional use tyre for the trailer axles.

EU Label Range

Fuel Efficiency Class	B
Wet Grip Class	B
External Rolling Noise Class and Measured Value (dB)	71-72

These values are for the full size range of these products. The special size range offered can vary from country to country. For detailed information on the sizes offered and the relevant parameters in your country, please refer to the table section, under the respective different categories (Highway / Regional).



Steer Axle

126S



YOKOHAMA's advanced steer tyre, designed for regional and highway operations.

- Serpentine and wavy grooves for traction, reduced shoulder step-down and irregular wear.
- Deep wavy sipes and shallow grooves for optimized contact pressure and anti-uneven-wear performance.
- Straight driving stability by rigid shoulder ribs with shallow design groove.
- Reduced stone bite and damage due to wavy grooves and stone ejectors.

EU Label Range	
Fuel Efficiency Class	C-D
Wet Grip Class	B
External Rolling Noise Class and Measured Value (dB)	A 68-70

These values are for the full size range of this product. The special size range offered can vary from country to country. For detailed information on the sizes offered and the relevant parameters in your country, please refer to the table section under the respective different categories (Regional / Highway).



M+S

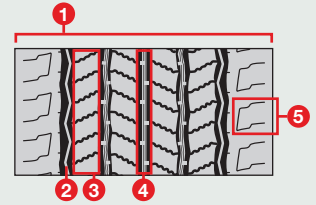

- 1 Wide tread design
- 2 Serpentine and wavy grooves
- 3 Deep wavy sipes and shallow grooves
- 4 Wavy grooves and stone ejectors
- 5 Rigid shoulder ribs with shallow design groove

Steer Axle All-Position

124R (124RA*)



Steer axle and all-position* tyre, developed for national and regional transport service.

- Wide tread design for tread life and traction. Serpentine and wavy grooves to reduce premature shoulder step-down and irregular wear.
- Deep wavy sipes and shallow grooves to improve traction and contact pressure/uneven wear performance.
- Wavy grooves and stone ejectors aiming to minimise stone holding and penetration. Rigid shoulder ribs with shallow design groove to improve shoulder step-down wear and straight driving stability.

124R

EU Label Range	
Fuel Efficiency Class	C-D
Wet Grip Class	B
External Rolling Noise Class and Measured Value (dB)	A 70-71

124RA

EU Label Range	
Fuel Efficiency Class	D
Wet Grip Class	B-C
External Rolling Noise Class and Measured Value (dB)	A 70-71

These values are for the full size range of these products. The special size range offered can vary from country to country. For detailed information on the sizes offered and the relevant parameters in your country, please refer to the table section (under the respective different categories [Regional / Coach] for 124R).



M+S

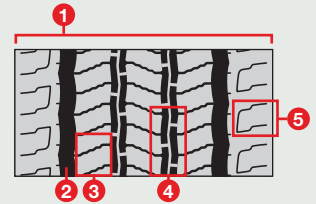

- 1 Wide tread design
- 2 Serpentine and wavy grooves
- 3 Deep wavy sipes and shallow grooves
- 4 Wavy grooves and stone ejectors
- 5 Rigid shoulder ribs with shallow design groove

Steer Axle All-Position

104ZR



"Zenvironment" steer axle and all-position tyre for national and regional transport service.

EU Label Range	
Fuel Efficiency Class	C-D
Wet Grip Class	B-C
External Rolling Noise Class and Measured Value (dB)	A 70

These values are for the full size range of this product. The special size range offered can vary from country to country. For detailed information on the sizes offered and the relevant parameters in your country, please refer to the table section.



Steer Axle All-Position

RY103



All-purpose, steer axle and all-position tyre for regional/city service.

EU Label Range	
Fuel Efficiency Class	C
Wet Grip Class	B
External Rolling Noise Class and Measured Value (dB)	B 73

These values are for the full size range of this product. The special size range offered can vary from country to country. For detailed information on the sizes offered and the relevant parameters in your country, please refer to the table section.

Drive Axle

704R



Drive axle tyre, engineered with advanced technologies for regional operation.

EU Label Range	
Fuel Efficiency Class	D-E
Wet Grip Class	B-C
External Rolling Noise Class and Measured Value (dB)	A-B 72-74

These values are for the full size range of this product. The special size range offered can vary from country to country. For detailed information on the sizes offered and the relevant parameters in your country, please refer to the table section.



M+S

Trailer Axle

Y785R



All purpose low platform trailer tyre.

- 5-rib tread design with straight grooves to enhance even wear.

EU Label Range	
Fuel Efficiency Class	C
Wet Grip Class	C
External Rolling Noise Class and Measured Value (dB)	B 73

These values are for the full size range of this product. The special size range offered can vary from country to country. For detailed information on the sizes offered and the relevant parameters in your country, please refer to the table section.

Trailer Axle

121T



Trailer Axle tyre designed for regional operations.

- Three grooves tread pattern design.
- Wavy grooves to minimise stone holding.
- Concave shallow grooves to provide traction.
- Step grooves to reduce stone bite and damage.
- Rigid shoulder ribs with shallow design groove to improve shoulder step-down wear and straight driving stability.

EU Label Range	
Fuel Efficiency Class	C
Wet Grip Class	B-C
External Rolling Noise Class and Measured Value (dB)	A 68-69

These values are for the full size range of this product. The special size range offered can vary from country to country. For detailed information on the sizes offered and the relevant parameters in your country, please refer to the table section.



M+S

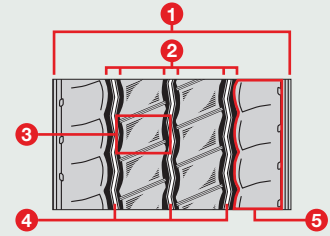

- 1 Three grooves tread pattern
- 2 Wavy grooves
- 3 Concave shallow groove
- 4 Step grooves
- 5 Rigid shoulder ribs with shallow design groove



Trailer Axle

125T



Tyre for regional service and trailer use.

- Designed for tread life and traction.
- Four main wavy grooves to reduce stone damage and to provide traction.
- Rigid shoulder ribs with shallow open lugs to improve shoulder step-down wear.
- Shallow sipes and open grooves for traction and contact pressure, aiming to avoid uneven wear performance.

EU Label Range	
Fuel Efficiency Class	C
Wet Grip Class	B-C
External Rolling Noise Class and Measured Value (dB)	B 73

These values are for the full size range of this product. The special size range offered can vary from country to country. For detailed information on the sizes offered and the relevant parameters in your country, please refer to the table section, under the respective different categories (Regional / Winter).



M+S

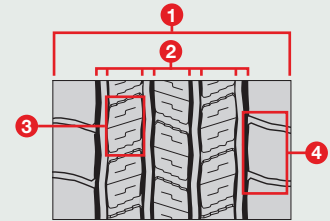

- 1 Advanced tread pattern
- 2 Four main wavy grooves
- 3 Shallow sipes and open grooves
- 4 Rigid shoulder ribs with shallow open lugs

Trailer Axle

RY357



Wide base highway/regional use tyre for the trailer axes.

The RY357 aims to deliver long mileage & shoulder wear resistance on trailer axle use.

- 5-rib tread design to enhance even wear and traction.
- Specially constructed casing makes this tyre well-suited for retreading.

EU Label Range	
Fuel Efficiency Class	B-C
Wet Grip Class	A-B
External Rolling Noise Class and Measured Value (dB)	A 68-69

These values are for the full size range of these products. The special size range offered can vary from country to country. For detailed information on the sizes offered and the relevant parameters in your country, please refer to the table section, under the respective different categories (Regional / Highway).

M+S

Depend on sizes

Trailer Axle

RY253



Wide base highway/regional use tyre engineered primarily for the trailer axes.

- 6-rib tread design to enhance even wear & traction.
- Specially constructed casing makes this tyre well-suited to retreading.

EU Label Range	
Fuel Efficiency Class	B
Wet Grip Class	B
External Rolling Noise Class and Measured Value (dB)	B 71-72

These values are for the full size range of these products. The special size range offered can vary from country to country. For detailed information on the sizes offered and the relevant parameters in your country, please refer to the table section, under the respective different categories (Regional / Highway).

City Bus ▶ Steer Axle // All-Position

120U



Steer axle and all-position tyre for city bus operation.

- Wide tread design for ground contact, even wear and traction.
- Step grooves and wavy grooves to reduce stone damage.
- Side wear indicator showing the usage limit.

EU Label Range	
Fuel Efficiency Class	C
Wet Grip Class	B
External Rolling Noise Class and Measured Value (dB)	A 69



These values are for the full size range of this product. The special size range offered can vary from country to country. For detailed information on the sizes offered and the relevant parameters in your country, please refer to the table section.



M+S

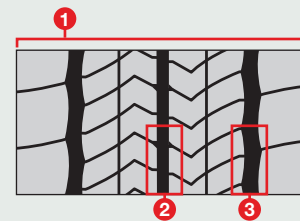

- 1 Wide tread design
- 2 Step Grooves
- 3 Wavy Grooves

City Bus ▶ Steer Axle // All-Position

RY537



Steer axle and all-position tyre for city bus operation.

- Deep tread with 4-rib design for mileage.
- Special sidewall protection to minimise tyre damage & abrasion from the kerb.

EU Label Range	
Fuel Efficiency Class	D
Wet Grip Class	B
External Rolling Noise Class and Measured Value (dB)	B 75

These values are for the full size range of this product. The special size range offered can vary from country to country. For detailed information on the sizes offered and the relevant parameters in your country, please refer to the table section.



M+S

Coach ▶ Steer Axle // All-Position

124R



Steer axle and all-position tyre, developed for national and regional transport service.

- Wide tread design for tread life and traction. Serpentine and wavy grooves to reduce premature shoulder step-down and irregular wear.
- Deep wavy sipes and shallow grooves to improve traction and contact pressure/uneven wear performance.
- Wavy grooves and stone ejectors aiming to minimise stone holding and penetration. Rigid shoulder ribs with shallow design groove to improve shoulder step-down wear and straight driving stability.

EU Label Range	
Fuel Efficiency Class	C-D
Wet Grip Class	B
External Rolling Noise Class and Measured Value (dB)	A 70-71

These values are for the full size range of this product. The special size range offered can vary from country to country. For detailed information on the sizes offered and the relevant parameters in your country, please refer to the table section, under the respective different categories (Coach / Regional).



M+S

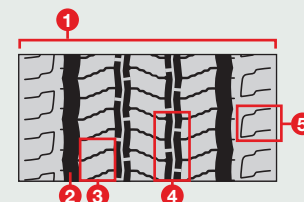

- 1 Wide tread design
- 2 Serpentine and wavy grooves
- 3 Deep wavy sipes and shallow grooves
- 4 Wavy grooves and stone ejectors
- 5 Rigid shoulder ribs with shallow design groove

Coach ▶ Steer Axle // All-Position

107ZL



Innovative highway steer and all-position tyre, engineered with innovative “Zenvironment” technologies for ordinal highway operations.

- Advanced tread compound under “Zenvironment” technology aims at mileage and fuel economy.
- YOKOHAMA’s casing compound under “Zenvironment” technology aims to extend casing life for multi-retread.
- The 5-rib tread design is perfect for steer position. With over 4,000 sipes, this premium feature aims to provide water evacuation and uniform wear.

EU Label Range	
Fuel Efficiency Class	C
Wet Grip Class	B
External Rolling Noise Class and Measured Value (dB)	B 71

These values are for the full size range of this product. The special size range offered can vary from country to country. For detailed information on the sizes offered and the relevant parameters in your country, please refer to the table section, under the respective different categories (Coach / Highway).

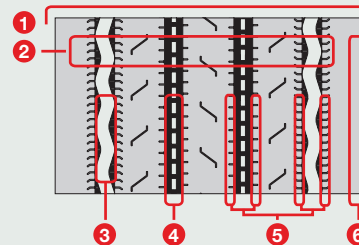

- 1 Tread design with special contoured design of the groove walls
- 2 Tread Compound / Deep Tread
- 3 Wavy Grooves
- 4 Stone Ejectors
- 5 SC (Stress-Wear Control)-Sipe
- 6 SC (Stress-Wear Control)-Groove

Steer Axle // All-Position

MY507



M+S

All-position tyre for on & off construction-site operation.

- Deep & wide tread to increase mileage.
- Stone ejectors & V-shaped grooves to decrease stone retention and to enhance the tyre's retreadability.



EU Label Range	
Fuel Efficiency Class	D-E
Wet Grip Class	A-B
External Rolling Noise Class and Measured Value (dB)	B 72-74

These values are for the full size range of this product. The special size range offered can vary from country to country. For detailed information on the sizes offered and the relevant parameters in your country, please refer to the table section, under the respective different categories (On and Off Road / Winter).

Steer Axle // All-Position

MY547

M+S

All-position tyre for on & off construction-site operation.

- Deep tread to produce mileage.
- 3 zig zag centre grooves with shoulder lugs for traction and to enhance smooth wear in local operation.



EU Label Range	
Fuel Efficiency Class	C
Wet Grip Class	B
External Rolling Noise Class and Measured Value (dB)	B 71-72

These values are for the full size range of this product. The special size range offered can vary from country to country. For detailed information on the sizes offered and the relevant parameters in your country, please refer to the table section.

Drive Axle

301C



M+S

Advanced drive axle tyre for on and off construction-site operation.

- Directional pattern with wide tread and deep groove design for tread life and traction.
- Expanding to centre Deep Lug groove.
- Aims to improve straight driving performance and durability by continuously arranged centre blocks design.
- Shoulder block shape designed to support off-road traction.



EU Label Range	
Fuel Efficiency Class	D
Wet Grip Class	B-C
External Rolling Noise Class and Measured Value (dB)	A 72-73

These values are for the full size range of this product. The special size range offered can vary from country to country. For detailed information on the sizes offered and the relevant parameters in your country, please refer to the table section.

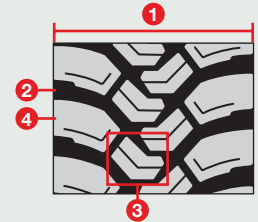

- 1 Wide tread and deep groove design
- 2 Expanding to center Deep Lug groove
- 3 Continuously arranged center blocks design
- 4 Shoulder block shape design

Drive Axle

LY717

M+S

Drive axle tyre for on & off construction-site operation engineered with advanced YOKOHAMA technologies.

- Deep & wide tread to increase the mileage.
- Tapered tread grooves to reduce stone retention.



EU Label Range	
Fuel Efficiency Class	D
Wet Grip Class	B
External Rolling Noise Class and Measured Value (dB)	B 74

These values are for the full size range of this product. The special size range offered can vary from country to country. For detailed information on the sizes offered and the relevant parameters in your country, please refer to the table section.

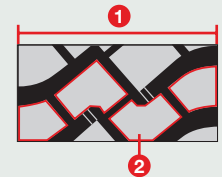

- 1 Deep & wide tread
- 2 Aggressive 4-block tread design

Trailer Axle // Steer Axle

505C



M+S

Advanced On and Off Road tyre for trailer axle and steer axle use.



EU Label Range	
Fuel Efficiency Class	B-C
Wet Grip Class	B-C
External Rolling Noise Class and Measured Value (dB)	B 72

These values are for the full size range of this product. The special size range offered can vary from country to country. For detailed information on the sizes offered and the relevant parameters in your country, please refer to the table section, under the respective different categories (On and Off Road / Winter).

Trailer Axle

508T



M+S

Winter trailer tyre with advanced YOKOHAMA technologies



EU Label Range	
Fuel Efficiency Class	D
Wet Grip Class	B
External Rolling Noise Class and Measured Value (dB)	B 72

These values are for the full size range of this product. The special size range offered can vary from country to country. For detailed information on the sizes offered and the relevant parameters in your country, please refer to the table section, under the respective different categories (On and Off Road / Winter).



Steer Axle // All-Position

901ZS

Innovative “Zenvironment” winter steer axle and all-position tyre.

- Traction block tread pattern with multi-sipes for traction.
- Rigid shoulder ribs with shallow open lugs to deliver even wear on the steer axle.
- SC-Sipes on block edges for even wear.
- YOKOHAMA’s winter tyre tread compound for mileage & traction.



EU Label Range	
Fuel Efficiency Class	D-E
Wet Grip Class	B-C
External Rolling Noise Class and Measured Value (dB)	B 74

These values are for the full size range of this product. The special size range offered can vary from country to country. For detailed information on the sizes offered and the relevant parameters in your country, please refer to the table section.

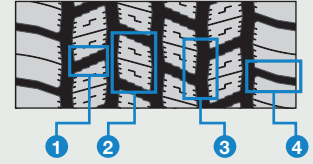

- 1 Specially-engineered Sub-groove Design
- 2 Traction Blocks with Multi-sipes
- 3 SC (Stress-Wear Control)-Sipes on block edges
- 4 Rigid Shoulder Ribs with Shallow Open Lugs

Drive Axle

902W

Winter drive axle tyre engineered with innovative “Zenvironment” technologies.

- Advanced designed tread pattern with Z shape block and Z shape closed sipe for traction.
- Waved grooves to reinforce the block stiffness in the lateral direction.



EU Label Range	
Fuel Efficiency Class	E
Wet Grip Class	B-C
External Rolling Noise Class and Measured Value (dB)	A 73

These values are for the full size range of this product. The special size range offered can vary from country to country. For detailed information on the sizes offered and the relevant parameters in your country, please refer to the table section.

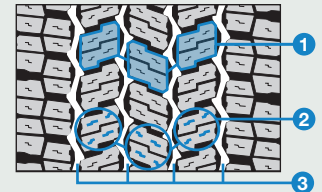

- 1 Z Shape Block for traction
- 2 Z Shape Closed Sipe for traction
- 3 Waved Groove to reinforce the lateral block stiffness

Drive Axle

SY397

Winter drive axle tyre developed using advanced technologies from YOKOHAMA.

- Deep & wide tread design.
- Aggressive tread pattern with multi sipes to deliver traction.



EU Label Range	
Fuel Efficiency Class	E
Wet Grip Class	C
External Rolling Noise Class and Measured Value (dB)	B 74

These values are for the full size range of this product. The special size range offered can vary from country to country. For detailed information on the sizes offered and the relevant parameters in your country, please refer to the table section.

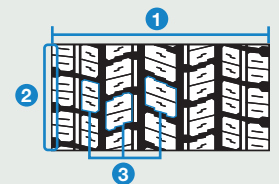

- 1 Deep & wide tread design
- 2 Semi-round shoulders
- 3 Aggressive traction pattern with multi sipes

Trailer Axle

125T



Winter tyre for trailer use.

- Designed for tread life and traction.
- Four main wavy grooves to reduce stone damage and to provide traction.
- Rigid shoulder ribs with shallow open lugs to improve shoulder step-down wear.
- Shallow sipes and open grooves for traction and contact pressure, aiming to avoid uneven wear performance.

EU Label Range	
Fuel Efficiency Class	C
Wet Grip Class	B-C
External Rolling Noise Class and Measured Value (dB)	B 73

These values are for the full size range of this product. The special size range offered can vary from country to country. For detailed information on the sizes offered and the relevant parameters in your country, please refer to the table section, under the respective different categories (Winter / Regional).

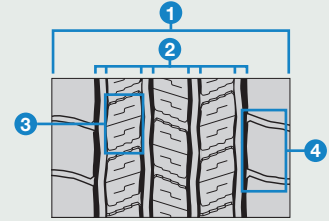

- 1 Advanced tread pattern
- 2 Four main wavy grooves
- 3 Shallow sipes and open grooves
- 4 Rigid shoulder ribs with shallow open lugs

Winter

Trailer Axle

508T



Winter trailer tyre with advanced YOKOHAMA technologies

- Tread pattern with three grooves.
- Wavy grooves for traction and less stone holding.
- Rigid center blocks with shallow lug grooves.
- Step grooves to protect the bottom of the grooves from stones.
- Rigid shoulder ribs with shallow lug groove to improve shoulder wear.

EU Label Range	
Fuel Efficiency Class	D
Wet Grip Class	B
External Rolling Noise Class and Measured Value (dB)	B 72

These values are for the full size range of this product. The special size range offered can vary from country to country. For detailed information on the sizes offered and the relevant parameters in your country, please refer to the table section, under the respective different categories (Winter / On and Off Road).

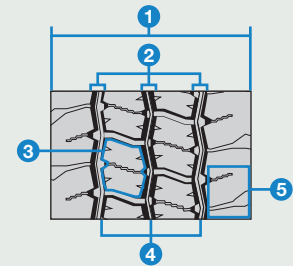

- 1 Tread Pattern with three grooves
- 2 Wavy grooves
- 3 Rigid center blocks with Shallow lug groove
- 4 Step grooves
- 5 Rigid shoulder ribs with shallow lug groove

Trailer Axle

505C



Advanced On and Off Road Winter tyre for trailer axle use.

- Tread pattern with wide block and rib.
- Wavy shallow lateral grooves for traction.
- Three wide circumferential grooves for water evacuation.
- Funnel shaped step grooves and high-strength belt construction, aiming for durability and the prevention of stone damage.

EU Label Range	
Fuel Efficiency Class	B-C
Wet Grip Class	B-C
External Rolling Noise Class and Measured Value (dB)	B 72

These values are for the full size range of this product. The special size range offered can vary from country to country. For detailed information on the sizes offered and the relevant parameters in your country, please refer to the table section, under the respective different categories (Winter / On and Off Road).

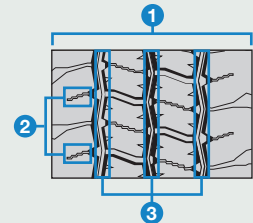

- 1 Wide tread pattern
- 2 Wavy shallow lateral grooves
- 3 Three wide circumferential grooves

Trailer Axle

MY507



Winter trailer tyre engineered with YOKOHAMA's advanced technologies.

- Deep & wide tread to increase mileage.
- Stone ejectors & V-shaped grooves to decrease stone retention and to enhance the tyre's retreadability.

EU Label Range	
Fuel Efficiency Class	D-E
Wet Grip Class	A-B
External Rolling Noise Class and Measured Value (dB)	B 72-74

These values are for the full size range of this product. The special size range offered can vary from country to country. For detailed information on the sizes offered and the relevant parameters in your country, please refer to the table section, under the respective different categories (Winter / On and Off Road).

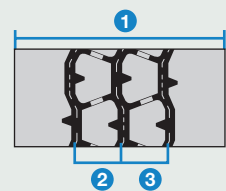

- 1 Deep & wide tread
- 2 3 wavy centre grooves
- 3 Stone ejectors & V-shaped grooves

EU Tyre Label

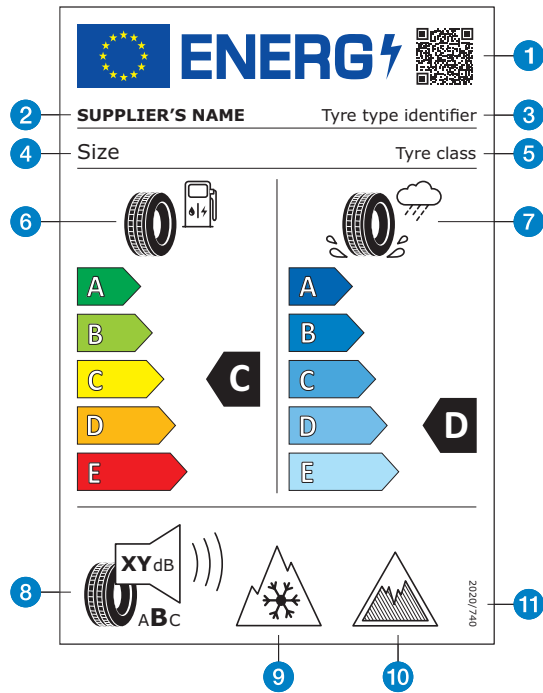

- 1 QR Code
- 2 Trade name or trademark of the supplier
- 3 Tyre type identifier = Article number in case of YOKOHAMA
- 4 Tyre size designation, load capacity index and speed category symbol
- 5 Tyre class: i.e. C1, C2 or C3
- 6 Fuel efficiency pictogram, scale and performance class
- 7 Wet grip pictogram, scale and performance class
- 8 External rolling noise pictogram, value (expressed in dB and rounded to the nearest integer) and performance class
- 9 Snow grip pictogram
- 10 Ice grip pictogram (C1 tyres only)
- 11 The serial number of this Regulation: "2020/740"

Since 2012 the EU Tyre Energy Label provides a clear and common classification of tyre performance for rolling resistance, braking on wet surfaces and external noise. The labels help consumers make informed decisions when they are buying tyres as they can easily set their priority choice based on the parameters.

Regulation (EC) No 1222/2009 first introduced the obligation of placing car and van tyres on the EU market with a sticker showing the label. That regulation was repealed and replaced by Regulation (EU) 2020/740 with start of application on 1 May 2021. It established a framework for the provision of harmonised information on tyre parameters through labelling to allow end-users to make an informed decision when purchasing tyres, for the purpose of increasing economic and environmental efficiency of road transport by promoting fuel-efficient, safe tyres with low noise levels.

Tyres are no longer allowed in classes F and G for rolling resistance and for wet grip, which is why the new scale has only 5 classes (A to E). The new energy symbols better suggest that the fuel efficiency is applicable to both internal combustion vehicles and to electric ones. In the bottom part, the external rolling noise class is always indicated, including the measured value of external noise level in decibels.



Fuel Efficiency Class

The fuel efficiency class ranges from A (most efficient) to E (least efficient). A top class tyre has less rolling resistance and therefore requires less energy to move the vehicle. This translates into lower energy costs (fossil fuels or electricity).



Wet Grip Class

The wet grip describes a tyre's performance under wet conditions and its classes ranges as well from A (shorter braking distance on wet asphalt) to E (longest).



External Rolling Noise Class and Measured Value (dB)

The external rolling noise class ranges from A (less noise outside the vehicle) to C (highest noise). The external rolling noise, caused by tyres, is measured in decibels. This noise is different from the "cavity noise", which is the noise transmitted from the rims to the interior of the car.

Under the new regulation, in addition to the previous tyre label, there are also options for including an icon relating to grip on icy conditions and/or severe snow conditions in the bottom part of the tyre label (next to the external rolling noise pictogram) for tyres which satisfy the minimum snow grip index values or the relevant minimum ice grip index values.



Tyres suitable for severe snow conditions bear the snow grip pictogram ("3 Peak Mountain Snowflake") or "alpine" symbol that is also present on the sidewall of such tyres. Nordic winter tyres (tyre class C1) for use on iced surfaces will feature a symbol (ice grip pictogram) that represents an ice stalagmite.

The QR code, to read with a smartphone or other suitable reader, is intended to provide this and additional information for each individual tyre type identifier via a link to the public part of the new European product database for Energy Labelling (EPREL). A link to this database is also provided via the YOKOHAMA website (www.yokohama.eu). You can also get the information of the database in printed form from your tyre dealer.

Other components of the label are the trade name or the trade mark of the supplier, the tyre type identifier, the tyre size designation, the load-capacity index and the speed category symbol, the tyre class and furthermore the serial number of the regulation (in the bottom part of the tyre label).

Regrooving Procedure

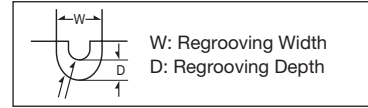

Regrooved pattern is shown in black.
Recut depth listed is maximum value.
Recut width listed has +1 mm tolerance.

Highway

BluEarth 110L

TYRE SIZE	DIMENSION OF REGROOVE	
	DEPTH (D)	WIDTH (W)
355/60R22.5	2.5 mm	7.0 mm
315/60R22.5	2.5 mm	7.0 mm

BluEarth 110L

TYRE SIZE	DIMENSION OF REGROOVE	
	DEPTH (D)	WIDTH (W)
315/80R22.5	2.5 mm	7.0 mm

BluEarth 707L

TYRE SIZE	DIMENSION OF REGROOVE	
	DEPTH (D)	WIDTH (W)
295/60R22.5	2.0 mm	7.0 mm
315/60R22.5	2.0 mm	7.0 mm
315/70R22.5	2.0 mm	7.0 mm
315/80R22.5	2.0 mm	7.0 mm

107ZL

TYRE SIZE	DIMENSION OF REGROOVE	
	DEPTH (D)	WIDTH (W)
315/70R22.5	2.5 mm	7.0 mm

107ZL

TYRE SIZE	DIMENSION OF REGROOVE	
	DEPTH (D)	WIDTH (W)
295/80R22.5	2.5 mm	7.0 mm
315/80R22.5	2.5 mm	7.0 mm

Highway

RY407

TYRE SIZE	DIMENSION OF REGROOVE	
	DEPTH (D)	WIDTH (W)
295/60R22.5	2.5 mm	7.0 mm

TY517E

TYRE SIZE	DIMENSION OF REGROOVE	
	DEPTH (D)	WIDTH (W)
295/80R22.5	3.0 mm	7.0 mm

Regional

124RA*/124R

TYRE SIZE	DIMENSION OF REGROOVE	
	DEPTH (D)	WIDTH (W)
205/75R17.5*	2.5 mm	7.0 mm
215/75R17.5*	2.5 mm	7.0 mm
225/75R17.5*	2.5 mm	7.0 mm
235/75R17.5*	2.5 mm	7.0 mm
245/70R17.5*	2.5 mm	7.0 mm
245/70R19.5*	2.5 mm	7.0 mm
245/70R19.5*	2.5 mm	7.0 mm
265/70R19.5*	2.5 mm	7.0 mm
285/70R19.5*	2.5 mm	7.0 mm
305/70R22.5*	2.5 mm	7.0 mm
315/60R22.5	2.5 mm	7.0 mm
315/70R22.5	2.5 mm	7.0 mm
295/80R22.5	2.5 mm	7.0 mm
315/80R22.5	2.5 mm	7.0 mm

104ZR

TYRE SIZE	DIMENSION OF REGROOVE	
	DEPTH (D)	WIDTH (W)
10R22.5	2.5 mm	7.0 mm
11R22.5	2.5 mm	7.0 mm
12R22.5	2.5 mm	7.0 mm

704R

TYRE SIZE	DIMENSION OF REGROOVE	
	DEPTH (D)	WIDTH (W)
245/70R17.5	2.0 mm	7.0 mm
205/75R17.5	2.0 mm	7.0 mm
215/75R17.5	2.0 mm	7.0 mm
225/75R17.5	2.0 mm	7.0 mm
235/75R17.5	2.0 mm	7.0 mm
265/70R19.5	2.0 mm	7.0 mm
285/70R19.5	2.0 mm	7.0 mm
295/60R22.5	2.0 mm	7.0 mm
315/60R22.5	2.0 mm	7.0 mm
315/70R22.5	2.0 mm	7.0 mm
295/80R22.5	2.0 mm	7.0 mm
315/80R22.5	2.0 mm	7.0 mm

Regional

RY103

TYRE SIZE	DIMENSION OF REGROOVE	
	DEPTH (D)	WIDTH (W)
275/70R22.5	2.5 mm	7.0 mm

121T

TYRE SIZE	DIMENSION OF REGROOVE	
	DEPTH (D)	WIDTH (W)
215/75R17.5	2.5 mm	7.0 mm
235/75R17.5	2.5 mm	7.0 mm
245/70R17.5	2.5 mm	7.0 mm
265/70R19.5	3.0 mm	7.0 mm
285/75R19.5	2.5 mm	7.0 mm

125T

TYRE SIZE	DIMENSION OF REGROOVE	
	DEPTH (D)	WIDTH (W)
385/55R22.5	2.5 mm	7.0 mm
385/65R22.5	2.5 mm	7.0 mm

Y785R

TYRE SIZE	DIMENSION OF REGROOVE	
	DEPTH (D)	WIDTH (W)
8.25R15	2.5 mm	7.0 mm

On and Off Road

MY507			MY507			MY547			301C			LY717		
Pattern when new			Pattern when new			Pattern when new			Pattern when new			Pattern when new		
Pattern when 70% worn			Pattern when 70% worn			Pattern when 70% worn			Pattern when 70% worn			Pattern when 70% worn		
Pattern after regrooved			Pattern after regrooved			Pattern after regrooved			Pattern after regrooved			Pattern after regrooved		
TYRE SIZE	DIMENSION OF REGROOVE		TYRE SIZE	DIMENSION OF REGROOVE		TYRE SIZE	DIMENSION OF REGROOVE		TYRE SIZE	DIMENSION OF REGROOVE		TYRE SIZE	DIMENSION OF REGROOVE	
	DEPTH (D)	WIDTH (W)		DEPTH (D)	WIDTH (W)		DEPTH (D)	WIDTH (W)		DEPTH (D)	WIDTH (W)		DEPTH (D)	WIDTH (W)
275/70R22.5	3.0 mm	7.0 mm	11R22.5	3.0 mm	7.0 mm	12.00R20	3.0 mm	7.0 mm	13R22.5	3.0 mm	7.0 mm	12.00R24	3.0 mm	7.0 mm
295/80R22.5	3.0 mm	7.0 mm	12R22.5	3.0 mm	7.0 mm	12.00R24	3.0 mm	7.0 mm	315/80R22.5	3.0 mm	7.0 mm	325/95R24	3.0 mm	7.0 mm
315/80R22.5	3.0 mm	7.0 mm	13R22.5	3.0 mm	7.0 mm	325/95R24	3.0 mm	7.0 mm						

Highway/Regional

126S			RY357			RY253			120U			RY537		
Pattern when new			Pattern when new			Pattern when new			Pattern when new			Pattern when new		
Pattern when 70% worn			Pattern when 70% worn			Pattern when 70% worn			Pattern when 70% worn			Pattern when 70% worn		
Pattern after regrooved			Pattern after regrooved			Pattern after regrooved			Pattern after regrooved			Pattern after regrooved		
TYRE SIZE	DIMENSION OF REGROOVE		TYRE SIZE	DIMENSION OF REGROOVE		TYRE SIZE	DIMENSION OF REGROOVE		TYRE SIZE	DIMENSION OF REGROOVE		TYRE SIZE	DIMENSION OF REGROOVE	
	DEPTH (D)	WIDTH (W)		DEPTH (D)	WIDTH (W)		DEPTH (D)	WIDTH (W)		DEPTH (D)	WIDTH (W)		DEPTH (D)	WIDTH (W)
355/60R22.5	2.5 mm	7.0 mm	385/55R22.5	2.5 mm	7.0 mm	425/65R22.5	2.5 mm	7.0 mm	275/70R22.5	2.5 mm	7.0 mm	11R22.5	2.5 mm	7.0 mm
385/55R22.5	2.5 mm	7.0 mm	385/65R22.5	2.5 mm	7.0 mm	445/65R22.5	2.5 mm	7.0 mm				295/80R22.5	2.5 mm	7.0 mm
385/65R22.5	2.5 mm	7.0 mm												

City Bus

Winter

901ZS			902W			SY397			MY507			508T		
Pattern when new			Pattern when new			Pattern when new			Pattern when new			Pattern when new		
Pattern when 70% worn			Pattern when 70% worn			Pattern when 70% worn			Pattern when 70% worn			Pattern when 70% worn		
Pattern after regrooved			Pattern after regrooved			Pattern after regrooved			Pattern after regrooved			Pattern after regrooved		
TYRE SIZE	DIMENSION OF REGROOVE		TYRE SIZE	DIMENSION OF REGROOVE		TYRE SIZE	DIMENSION OF REGROOVE		TYRE SIZE	DIMENSION OF REGROOVE		TYRE SIZE	DIMENSION OF REGROOVE	
	DEPTH (D)	WIDTH (W)		DEPTH (D)	WIDTH (W)		DEPTH (D)	WIDTH (W)		DEPTH (D)	WIDTH (W)		DEPTH (D)	WIDTH (W)
385/55R22.5	2.5 mm	7.0 mm	275/70R22.5	2.5 mm	7.0 mm	315/70R22.5	3.0 mm	7.0 mm	275/70R22.5	3.0 mm	7.0 mm	265/70R19.5	3.0 mm	7.0 mm
385/65R22.5	2.5 mm	7.0 mm	315/70R22.5	2.5 mm	7.0 mm	295/80R22.5	3.0 mm	7.0 mm						
275/70R22.5	2.5 mm	7.0 mm	295/80R22.5	2.5 mm	7.0 mm	315/80R22.5	3.0 mm	7.0 mm						
315/70R22.5	2.5 mm	7.0 mm	315/80R22.5	2.5 mm	7.0 mm									
295/80R22.5	2.5 mm	7.0 mm												
315/80R22.5	2.5 mm	7.0 mm												

Winter/On and Off Road

505C		
Pattern when new		
Pattern when 70% worn		
Pattern after regrooved		
TYRE SIZE	DIMENSION OF REGROOVE	
	DEPTH (D)	WIDTH (W)
385/65R22.5	3.0 mm	7.0 mm
425/65R22.5	2.5 mm	7.0 mm



LOAD AND INFLATION PRESSURE TABLE (I)

Inch	Size	LI	Single / Dual	kPa / bar / psi								
				500	550	600	625	650	675	700	725	
				5.00	5.50	6.00	6.25	6.50	6.75	7.00	7.25	
				73	80	87	91	94	98	102	105	
15	7.50R15	135/133	S					3520		3735		
			D				6650		7055			
	8.25R15	142/141	S					4275		4540		
			D				8310		8820			
17.5	245/70R17.5	146/146	S									
			D									
		143/141	S									
			D									
	136/134	S					3615		3835			
		D					6840		7260			
	205/75R17.5	124/122	S			2675		2855		3030		
			D			5020		5350		5680		
	215/75R17.5	135/133	S							3735		
			D							7055		
		126/124	S	2600	2805	3005		3205		3400		
			D	4890	5275	5655		6030		6400		
	225/75R17.5	129/127	S	2750	2965	3180		3390		3600	3700	
			D	5200	5610	6015		6415		6805	7000	
	235/75R17.5	145/145	S							4850		
			D							9705		
143/141		S										
		D										
132/130		S					3475		3685			
		D					6600		7005			
19.5	245/70R19.5	136/134	S					3700		3930		
			D					7010		7435		
		133/131	S			3445		3675		3900		
			D			6525		6955		7380		
265/70R19.5	143/141	S							4665			
		D							8820			
	140/138	S			4075		4345		4610			
		D			7690		8200		8700			
285/70R19.5	150/148	S										
		D										
	146/144	S										
		D										
20	12.00R20	154/150	S							6420		
			D							11470		
	365/80R20	160	S									
		158	S									
22.5	9R22.5	136/134	S					3700		3930		
			D					7010		7435		
	10R22.5	144/142	S							4795		
			D							9075		
	11R22.5	151/148	S							5905		
			D							10785		
		148/145	S							5395		
			D							9930		
	12R22.5	152/148	S							6080		
			D							10785		
	13R22.5	156/150	S							6690		
			D							11210		
		154/150	S							6420		
			D							11470		
	355/50R22.5	156	S									
	295/60R22.5	150/147	S									
			D									
	315/60R22.5	154/148	S									
			D									
		152/148	S									
			D									
	275/70R22.5	152/148	S									
			D									
		150/148	S									
D												
148/145		S										
		D										
305/70R22.5	152/150	S										
		D										
	150/148	S							5735			
		D							10785			

LOAD AND INFLATION PRESSURE TABLE (II)

Inch	Size	LI	Single / Dual	kPa / bar / psi								
				500	550	600	625	650	675	700	725	
				5.00	5.50	6.00	6.25	6.50	6.75	7.00	7.25	
				73	80	87	91	94	98	102	105	
22.5	315/70R22.5	156/150	S									
			D									
		154/150	S									
			D									
		152/148	S								6080	
			D									10785
	275/80R22.5	149/146	S								5565	
			D								10275	
	295/80R22.5	154/150	S								6420	
			D								11470	
		154/149	S								6420	
			D								11130	
		152/148	S								6080	
			D								10785	
	315/80R22.5	156/150	S								6850	
			D								11470	
		154/150	S					6200			6575	
			D					11075			11750	
	385/55R22.5	160	S								7360	
		158	S								7275	
385/65R22.5	164	S										
	160	S										
425/65R22.5	165	S					8510			9030		
	168	S					9035			9590		
24	12.00R24	160/156	S					7260		7705		
			D					12910		13700		
		156/153	S					6950		7375		
			D					12685		13460		
	325/95R24	162/160	S					7665		8135		
			D					14525		15410		

FOR YOUR COMFORT AND SAFETY

Tyre Selection Reference	Axle Position			Road Conditions
Type of Operation				Unpaved road rate
	Steer	Drive	Trailer	
Highway	110L, 107ZL, RY407, 126S	110L, 107ZL, RY407, 707L, TY517E	RY357, RY253	-
Regional	126S, 124R, 104ZR, RY103	124RA, 104ZR, RY103, 704R	121T, 125T, RY357, RY253, Y785R	-
City Bus	120U, RY537	120U, RY537	-	-
Coach	107ZL, 124R	107ZL, 124R	-	-
On and Off Road	MY507, MY547, 505C	MY507, MY547, 301C, LY717	505C, 508T	less than 20%
Winter	901ZS	901ZS, 902W, SY397	125T, 508T, 505C, MY507	-

* Do not mix different tyre size designations or constructions on the same axle. Always use the tyres for their intended service purpose.

* Some vehicles require specialised tyre fitment. Please consult your YOKOHAMA distributor for details.

* Under normal highway conditions, the steer tyres above can also be used on the drive axles.

* The availability of products shown in this table may vary from country to country.

Please consult your YOKOHAMA distributor for local availability.

The local regulations for the proper usage of Car Tyres may differ from country to country. Please make sure to check foreign regulations carefully, before going abroad. Fuel saving and road safety depend heavily on the behaviour of drivers and in particular on the following: eco driving can significantly reduce fuel consumption; tyre pressure needs to be regularly checked to optimise fuel efficiency and wet grip; stopping distances must always be respected. Ice grip tyres are specifically designed for road surfaces covered with ice and compact snow, and should only be used in very severe climate conditions (e.g. cold temperatures). Using ice grip tyres in less severe climate condition (e.g. wet conditions or warmer temperatures) could result in sub-optimal performance, in particular for wet grip, handling and wear.

kPa / bar / psi						
750	775	800	825	850	875	900
7.50	7.75	8.00	8.25	8.50	8.75	9.00
109	112	116	120	123	127	131
6915		7280		7640		8000
11580		12195		12800		13400
6480		6825		7165		7500
11580		12195		12800		13400
6425		6765		7100		
11400		12005		12600		
5880		6190		6500		
10855		11430		12000		
6785		7145		7500		
12125		12765		13400		
6785		7145		7500		
11760		12385		13000		
6425		6765		7100		
11400		12005		12600		
7240		7620		8000		
12125		12765		13400		
6950		7320	7500			
12415		13075	13400			
7780		8190		8600		9000
7690		8100		8500		
8645		9100		9555		10000
7780		8190		8600		9000
7690		8100		8500		
9545		10050	10300			
10135		10670		11200		
8140		8575		9000		
14475		15245		16000		
7795	8000					
14220	14600					
8595		9050		9500		
16285		17150		18000		

This table shows the load-capacity (kg) per axle at tyre pressure (kPa / bar / psi) for normal operation. Some vehicle operations require specialised inflation pressure. Please contact your YOKOHAMA distributor for details.

USER INFORMATION: Only specially trained personnel should mount tyres. Failure to comply with these tyre demounting/mounting safety precautions can cause the bead to break and the assembly to burst with sufficient force to cause serious injury or death.

- Always deflate tyre completely before removing lock or side rings.
 - Never use wheels of different manufacturers or different sizes.
 - Never mount tyres on wheels which are damaged or not smooth and clean.
 - Always clean and inspect wheel. Lubricate beads (and rim flanges for tubeless types), tube and rim side of flap with an approved rubber lubricant.
 - Always be sure that wheel components are properly seated before inflating.
 - Always use an extension hose with gauge and clip-on chuck.
 - Never inflate beyond 1.5 bar prior to placing tyre/wheel assembly in a safety cage.
 - Always use a safety cage or other restraining device when inflating the tyre to seat the beads and/or inflating the tyre to normal operating inflation pressure.
 - Never stand, lean or reach over the assembly during inflation.
 - After beads are fully seated, adjust to vehicle manufacturer's recommended inflation pressure.
 - Never mount radials on the same axle with bias tyres. Follow vehicle manufacturer's recommendations.
 - Tyres must be removed when remaining tread depth reaches regulated minimum tread pattern in a country.
 - Winter tyres have "Platform Indicators" in the grooves, marked with an arrow on the sidewall, which indicates their location.
 - Winter tyres can no longer be used as winter tyres after the "Platform Indicators" have appeared on the tread surface. This occurs when the original tread depth has approximately 50% wear.
 - Stones, gravel and other foreign objects stuck in the tyre treads may damage the tyre. Remove foreign objects from the treads.
 - Objects in the road such as potholes, glass, metal, rocks, wood debris, kerbstones and others that could damage a tyre should be safely avoided.
 - To preserve traffic safety and tyre life, YOKOHAMA recommends driving safely and avoiding hard acceleration, braking or cornering in unnecessary situations.
 - If you feel the vehicle is unstable or feel/hear any unusual vibrations/noises, stop your vehicle in a safe place and inspect your tyres. Even if no visible defects are found, drive slowly and ask your tyre dealer to inspect your tyres as soon as possible.
- Never use a tyre under the following conditions and replace a tyre immediately:**
- If the tread has worn to the tread wear indicator.
 - If breaks in the fabric appear.
 - If cords or wires are exposed.

Moisture in a tyre can damage the casing. Store tyres in a dry area. Dry interior before mounting. Inflate with dry air.

